

EVOLUTION[™]

STEEL PERGOLAS

TABLE OF CONTENTS

Introduction

General Guidelines.....	3
Required Tools/Components.....	4

Installation

Overall Dimension.....	6
Project Planning.....	6
Pergola Assembly	
Mount Post to Pier Brackets onto Ground Surface.....	8
Mount F-50 Brackets & Post Caps onto Posts	9
Mount F-50 Brackets onto Long Frame Joists.....	9
Mount Short Frame Joists onto Posts.....	11
Mount Posts into Each Post to Pier Bracket.....	13
Mount Long Frame Joists onto Posts.....	14
Mount Rafter Joists Between Two Frame Joists.....	16
Mount Lateral Bracing Brackets into Lateral Bracing Support.....	18
Mount Lateral Bracing Assembly onto Posts and Frame Joists.....	19
Apply Spray Paint to Scratched Areas.....	20

Care & Maintenance/Warranty.....	21
----------------------------------	----

INTRODUCTION

READ INSTRUCTIONS COMPLETELY BEFORE STARTING INSTALLATION

General Guidelines

It is the responsibility of the installer to meet all code and safety requirements, and to obtain all required building permits. The pergola installer should determine and implement appropriate installation techniques for each installation situation. Neither Fortress Building Products nor its distributors shall not be held liable for improper or unsafe installations.

Personal Protection Equipment (PPE) must be worn anytime you're using power tools and working with Evolution Pergola Kit. Eye protection, hearing protection, closed-toe shoes, gloves, long sleeves, and pants must be worn to keep yourself safe.

As the steel pergola parts are cut, all metal shavings and/or chips must be removed from inside the Evolution Pergola Kit parts. At the end of a work period, all steel shavings and/or chips must be cleaned off the job site. Not doing so could result in the staining of surrounding surfaces.

As the steel pergola parts are cut, **DO NOT** allow metal shavings and/or chips to get dropped or blown into a pool, hot tub, or any other body of water. Staining could occur if this were to happen.

Fortress Building Products **DOES NOT** cover all possible installation scenarios within these instructions. In some cases, it may be necessary for you to consult a professional engineer, building code official, or local dealer. In addition, it may become necessary to use brackets other than Fortress' when more complex installations take place.

Required Tools



Goggles



Safety
Gloves



Tape
Measure



Speed
Square



Level



Pencil



String



Ear
Protector



Close-Toed
Shoes



Touch-Up
Paint



Bit
Extender



Speed
Clamps



Drill



Hex Head Nut Driver Bits:
9/16", 5/16" [14mm, 8mm]



Step
Ladders



Ratchet Wrench:
9/16" [14mm]



Wrench:
9/16" [14mm]



Concrete Anchor:
3/8" x 3" [10mm x 76mm]

Components

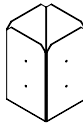

A: Post to Pier Bracket (x4)

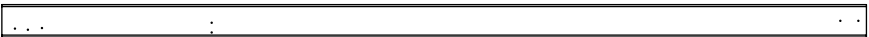

B: Post (x4)

3-1/2" x 3-1/2" x 96"



C: F-50 (x8)

Post to Framing Joists

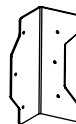

D: F-50 (x14)

Framing to Rafter Joists

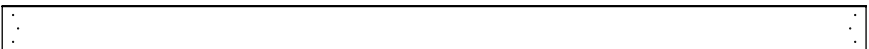

E: Short Framing Joist (x2)

2" x 6" x 88-11/16" [51mm x 152mm x 2253mm]

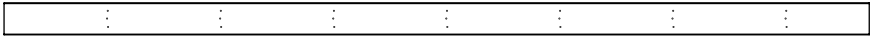

F: Long Framing Joist (x2)

2" x 6" x 136-11/16" [51mm x 152mm x 3472mm]

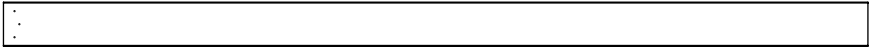

G: Rafter Joist (x7)

2" x 6" x 91-15/16" [51mm x 152mm x 2335mm]



H: Lateral Bracing Bracket (x16)



I: Lateral Bracing Support(x8)

2" x 2" x 24" [51mm x 152mm x 610mm]

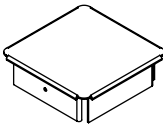

J: Post Cap (x4)

3-1/2" x 3-1/2" [89mm x 89mm]



K: Evolution Self-drilling Screw (Bag of 250)

3/4" [19mm] #12

Note:

- 212 screws (Component K) are required to complete an installation. Additional screws are provided to account for damaged or lost screws.
- Components **ARE NOT** show to scale.

Stickers on Components

A: Post to Pier Bracket

B: Post

C: F-50 (Post to Framing Joists)

D: F-50 (Framing to Rafter Joists)

E: Short Framing Joist

F: Long Framing Joist

G: Rafter Joist

H: Lateral Bracing Bracket

I: Lateral Bracing

J: Post Cap

K: Evolution Self-drilling Screw

OVERALL DIMENSIONS

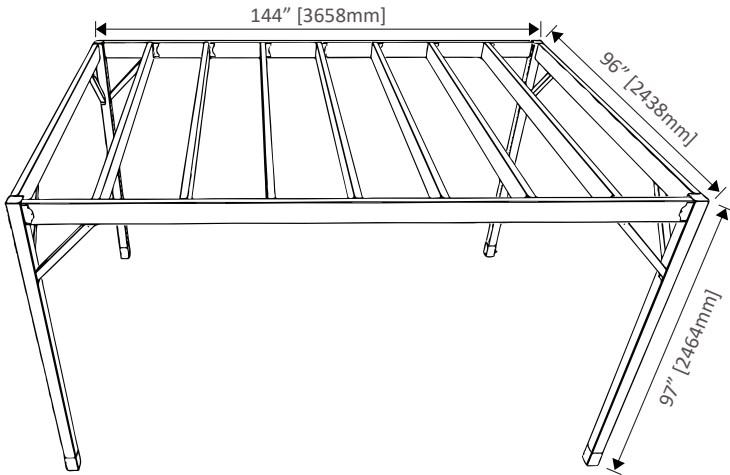

PROJECT PLANNING

Step 1: Create a Perimeter For The Pergola

1. This Evolution Pergola Kit is designed to have a perimeter of 144" x 96" [3658mm x 2438mm].
2. Using Stakes and Guide String create a perimeter for the pergola. Each side of the pergola should be positioned a minimum of 4" [102mm] from the edge of the ground surface. As shown in Fig. 1.

Tip:

- Before starting the pergola project, confirm that the ground surface is level and square.
- Be sure corners are set at 90° angles.

Fig. 1

Top View

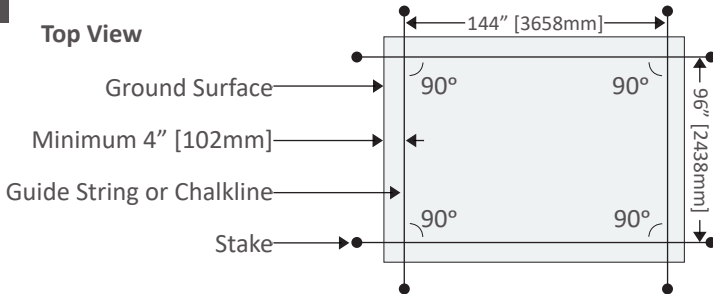

Step 2: Mark Post to Pier Bracket Locations

1. Position Post to Pier Brackets (component A) along internal corners of Guide Strings. As shown in Fig. 2.
2. Using a pencil, mark bolt hole locations.

Tip:

- **For a successful installation, confirm the created perimeter with Post to Pier Brackets is accurate and square.**
- **How To Square Perimeter:** Fortress recommends using the 3-4-5 rule. Measure and mark 3' [914mm] & 4' [1219mm] from the starting point along guide string, then measure between two markings. Adjust until measurement between markings is exactly 5' [1524mm]. As shown in Fig. 2. Larger triangles, with sides of 6-8-10 and 9-12-15, allow for even more accurate results.

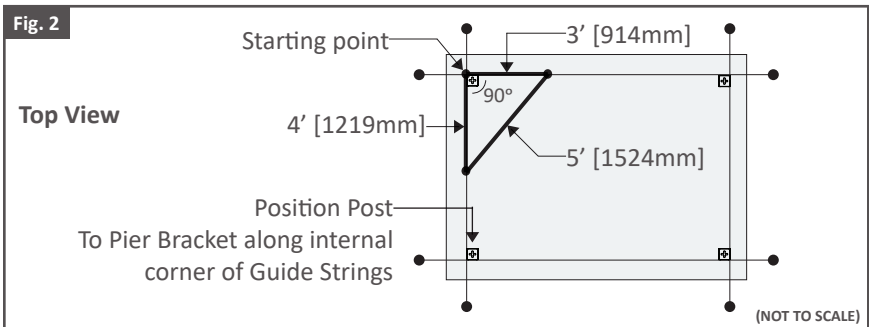

PERGOLA ASSEMBLY

Step 1: Mount Post to Pier Brackets (x4) onto Ground Surface

1. Confirm the Post to Pier Brackets (component A) are in desired positioned. Adjust if needed. **For a successful installation, It is critical for Post to Pier Brackets to be square and positioned correctly.** Reference project planning on pages 6 and 7.
2. Mount Post to Pier Brackets (component A) onto the ground surface using 3/8" [10mm] Concrete Anchors. As shown in Fig. 3 & 4.

Note:

- Reference Fig. 5 for mounted Post to Pier Brackets.
- Stickers should be covered by mating components if install correctly.

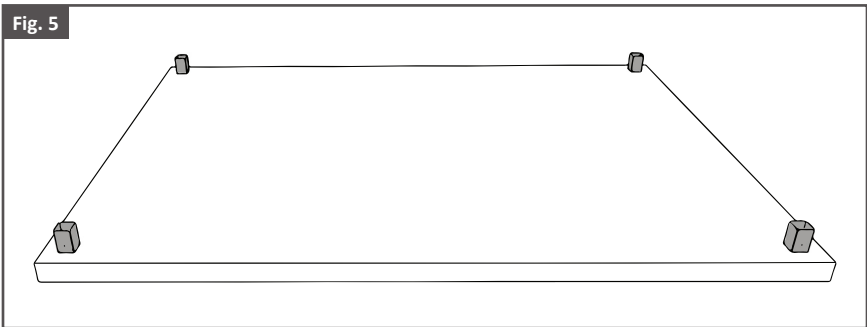
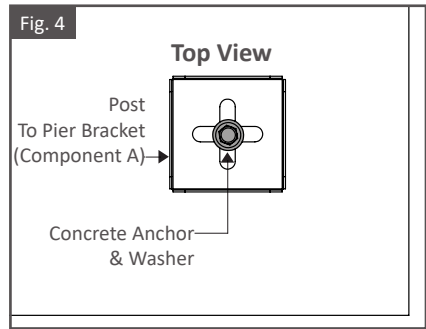
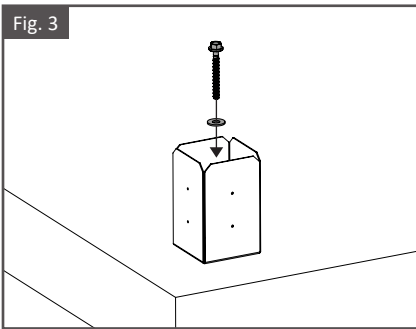

Step 2: Mount F-50 Brackets (x8) & Post Caps (x4) onto Posts (x4)

1. Mount two F-50 Brackets (component C) and one Post Cap (component J) to each Post (component B). As shown in Fig. 6.
2. Fasten using 7 Evolution Self-drilling Screws (component K) per two F-50 Brackets and Post Cap. As shown in Fig. 7.

Note:

- Reference Fig. 8 for mounted F-50 Brackets and Post Caps.
- Stickers should be covered by mating components if install correctly.
- **Be sure pre-drilled holes on the F-50 Brackets and the Posts are aligned before fastening.**

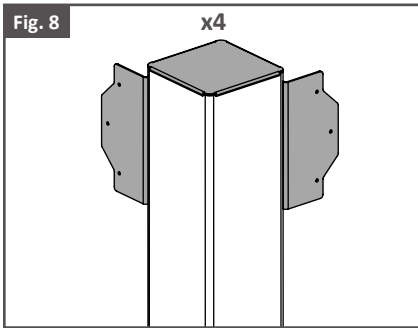
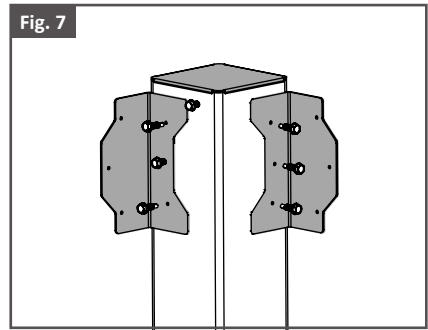
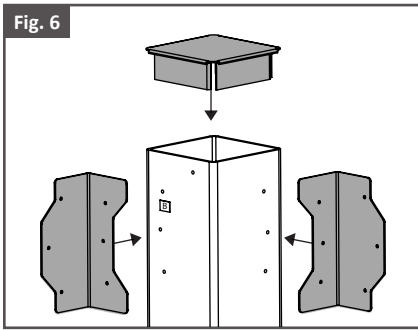

Step 3: Mount F-50 Brackets (x7) onto Long Frame Joists (x2)

1. Attach the F-50 Brackets (component D) onto the inside faces of the two pre-drilled Long Frame joists (component F). Fasten using 3 Evolution Self-drilling Screws (component K) per F-50 Bracket. As shown in Fig. 9 - 11.

Note:

- Reference Fig. 12 for mounted F-50 Brackets.
- Stickers should be covered by mating components if install correctly.
- **Be sure pre-drilled holes on the Long Frame Joists and the F-50 Brackets are aligned before fastening.**
- **DO NOT** mount F-50 Brackets onto the outside face of the Long Frame Joist in this step. As shown in fig. 13

Fig. 9

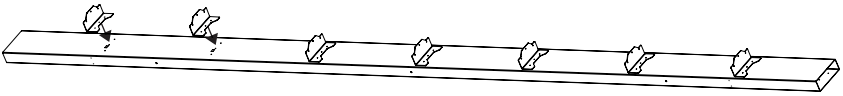

Fig. 10

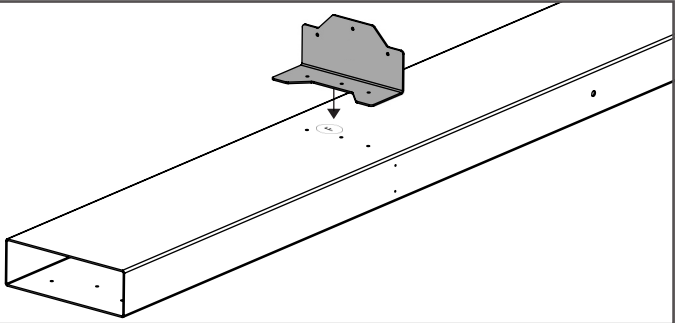

Fig. 11

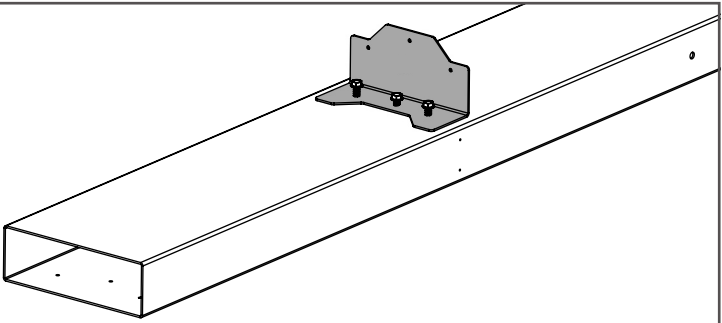

Fig. 12

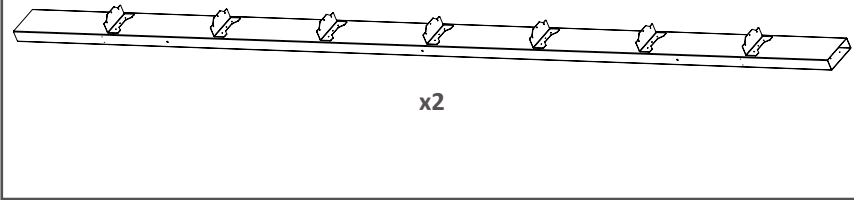
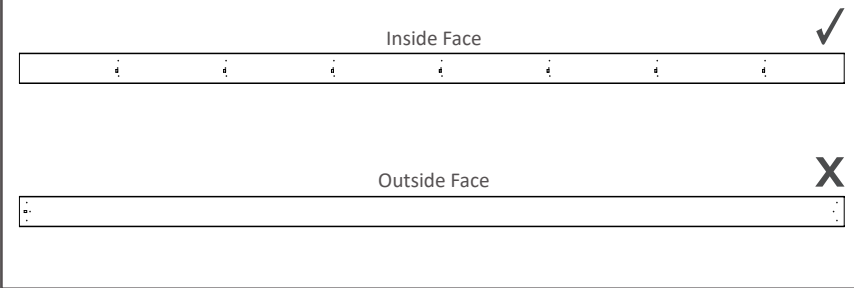

Fig. 13



Step 4: Mount Short Frame Joists (x2) onto Posts (x4)

1. Mount each Short Frame Joist (Component E) onto F-50 Brackets (component C) that are attached to Posts (component B). As shown in Fig. 14 & 15.
2. Be sure drainage holes and pre-drilled screw holes on the Short Frame Joists face down once installed. As shown in Fig. 16. Adjust if required.
3. Fasten using 3 Evolution Self-drilling Screws (component K) per F-50 Bracket. As shown in Fig. 17.

Note:

- Reference Fig. 18 for mounted Short Frame Joists.
- Stickers should be covered by mating components if install correctly.
- **Be sure pre-drilled holes on the Short Frame Joists and the F-50 Brackets are aligned before fastening.**

Fig. 14

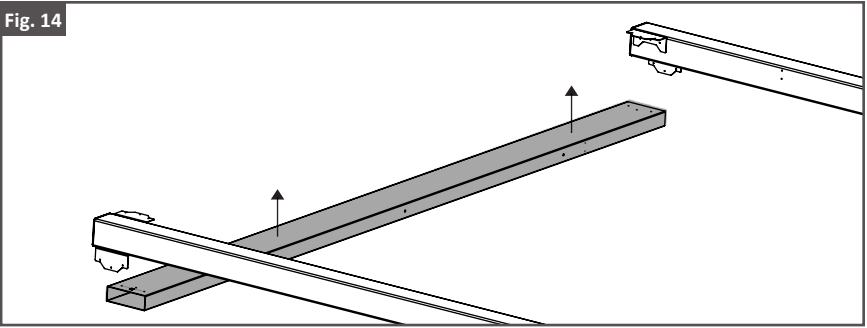

Fig. 15

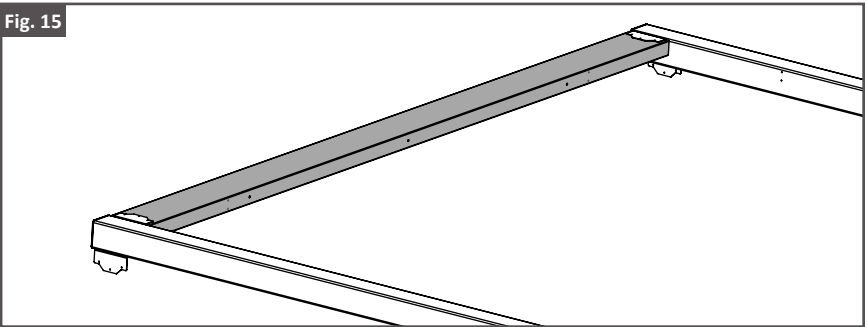

Fig. 16

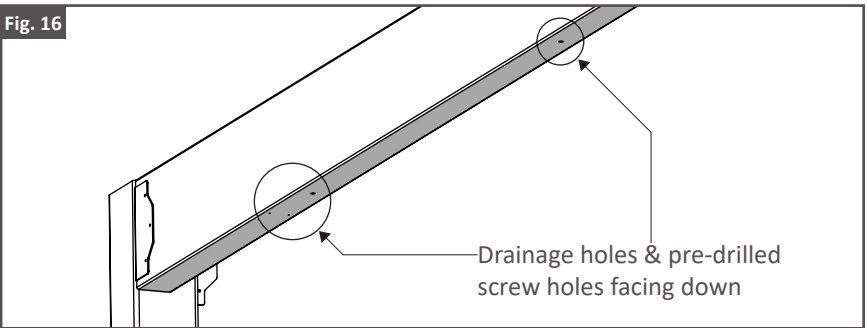

Fig. 17

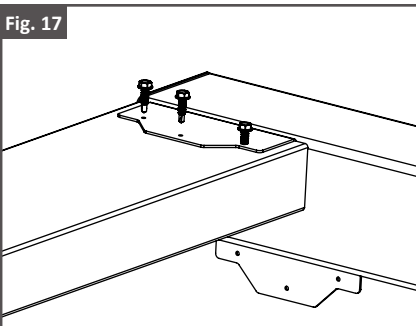
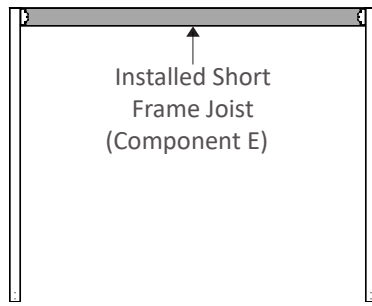

Fig. 18

Front View



x2

Step 5: Mount Posts (x4) into Each Post to Pier Bracket (x4)

1. Insert the two Short Frame Joist & Post assemblies (Step 4) into the mounted Post the Pier Brackets (component A). As shown in Fig. 19 & 20.
2. Fasten using 8 Evolution Self-drilling Screws (component K) per Post to Pier Bracket. As shown in Fig. 21.

Note:

- Reference Fig. 22 for mounted Post to Pier Brackets and Short Frame Joists.
- Stickers should be covered by mating components if install correctly.
- A minimum of **TWO** people will be required to complete this step.
- **Be sure pre-drilled holes on the posts and the Post to Pier Brackets are aligned before fastening.**

Fig. 19

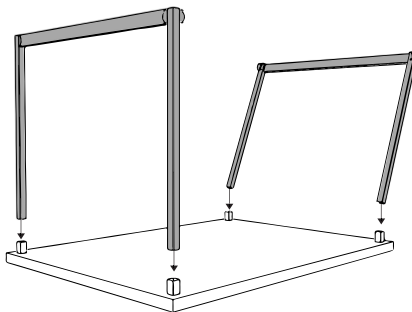

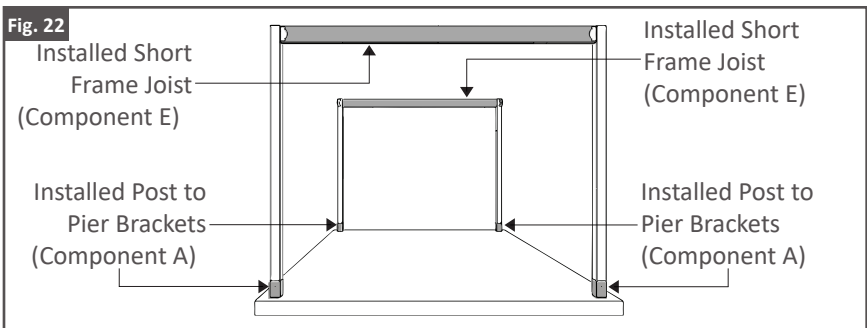
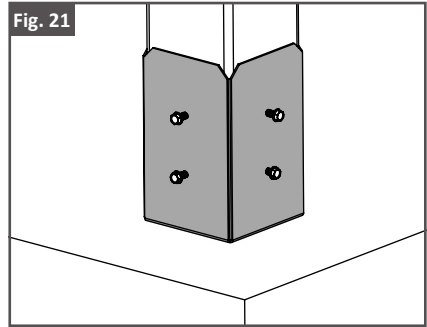
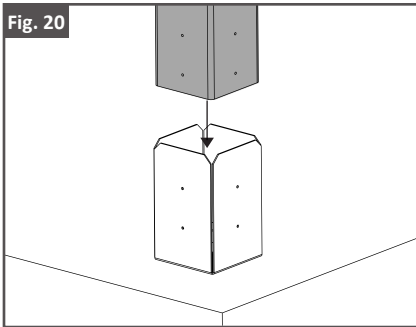

Step 6: Mount Long Frame Joists (x2) onto Posts (x4)

1. Mount each Long Frame Joist (Component F) onto F-50 Brackets (component C) that are attached to Posts (component B). As shown in Fig. 23 & 24.
2. Be sure drainage holes and pre-drilled screw holes on the Long Frame Joists face down once installed. As shown in Fig. 25. Adjust if required.
3. Fasten using 3 Evolution Self-drilling Screws (component K) per F-50 Bracket. As shown in Fig. 26.

Note:

- Reference Fig. 27 for mounted F-50 Brackets.
- Stickers should be covered by mating components if install correctly.
- **Be sure pre-drilled holes on the Long Frame Joists and the F-50 Brackets are aligned before fastening.**

Fig. 23

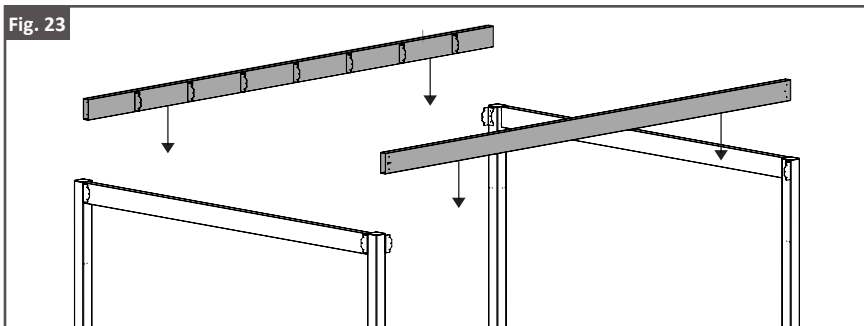

Fig. 24

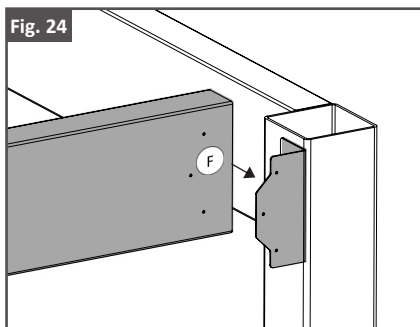

Fig. 25

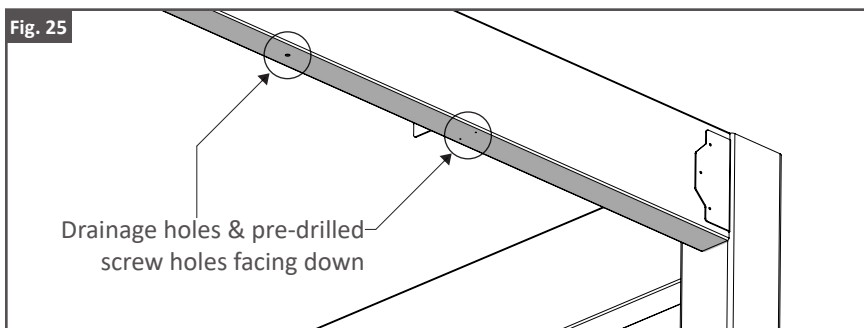

Fig. 26

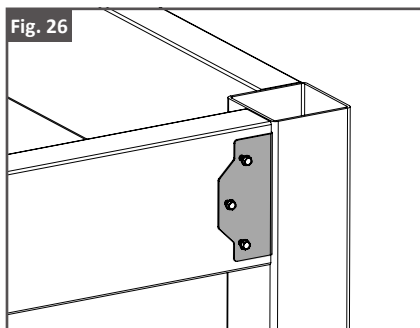
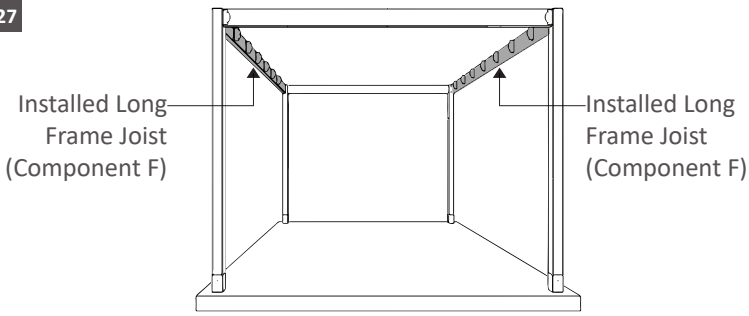

Fig. 27



Step 7: Mount Rafter Joists (x7) Between Two Long Frame Joists

1. Mount each Rafter Joist (Component G) onto F-50 Brackets (component D) that are attached to Long Frame Joists (Component F). F-50 Brackets will be mounted on opposite faces of the Rafter Joist. As shown in Fig. 28 - 30.
2. Be sure drainage holes and pre-drilled screw holes on the Rafter Joists face down once installed. As shown in Fig. 31. Adjust if required.
3. Fasten using 3 Evolution Self-drilling Screws (component K) per F-50 Bracket. As shown in Fig. 32.

Note:

- Clamps can be used to temporarily hold Rafter joists onto Frame Joist & F-50 Brackets. As shown in Fig. 33.
- Reference Fig. 34 for mounted Rafter Joists.
- Stickers should be covered by mating components if install correctly.
- A minimum of **THREE** people will be required to complete this step.
- **Be sure pre-drilled holes on the Rafter Joists and the F-50 Brackets are aligned before fastening.**

Fig. 28

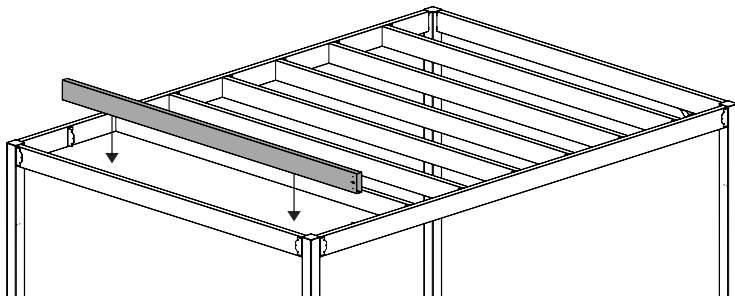

Fig. 29

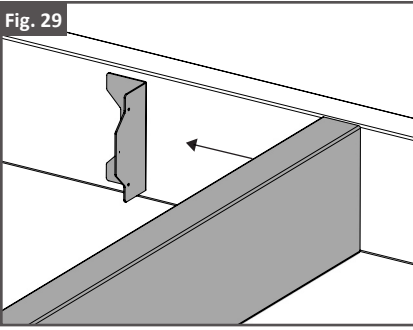

Fig. 30

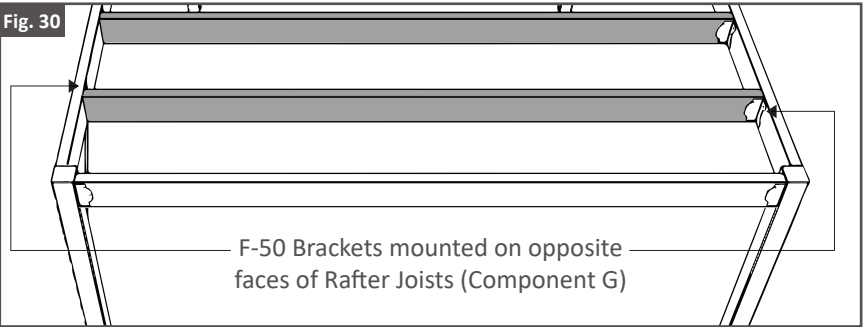

Fig. 31

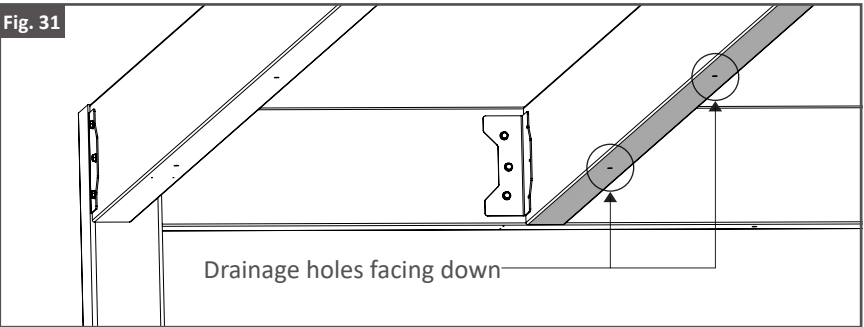

Fig. 32

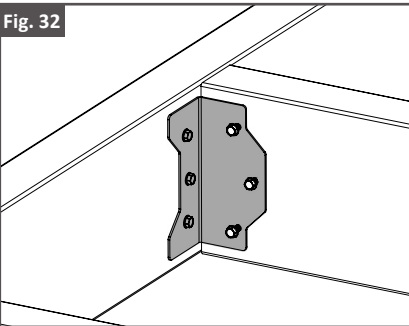

Fig. 33

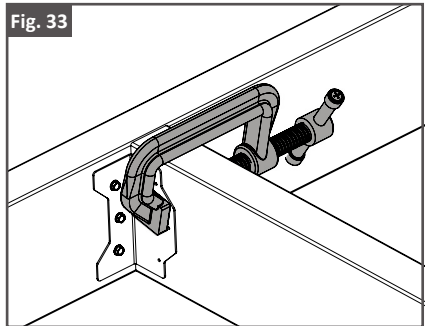
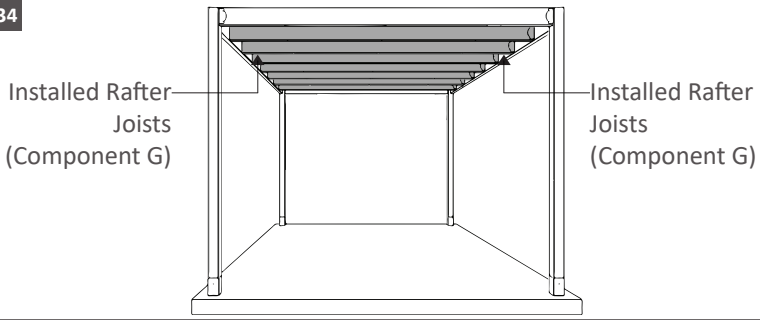

Fig. 34



Step 8: Mount Lateral Bracing Brackets (x16) into Lateral Bracing Supports (x8)

1. Insert two Lateral Bracing Brackets (component H) into both ends of each Lateral Bracing Support (Component I). As shown in Fig. 35.

Note:

- **DO NOT** fasten Lateral Bracing Brackets onto the Lateral Bracing Support in this step.
- Reference Fig. 36 for assembled Lateral Bracing.
- Stickers should be covered by mating components if install correctly.

Fig. 35

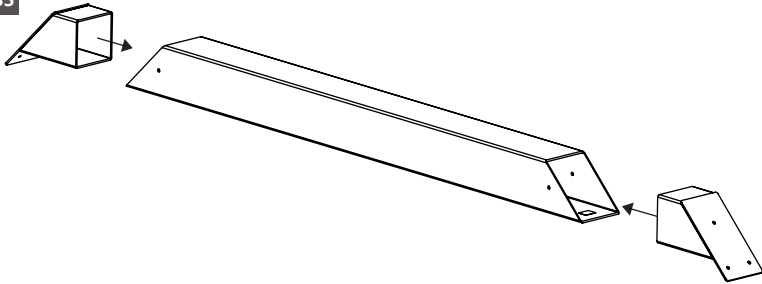
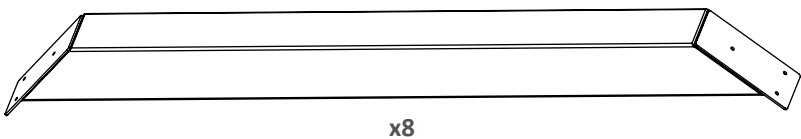

Fig. 36



Step 9: Mount Lateral Bracing Assemblies (x8) onto Posts and Frame Joists

1. Mount two Lateral Bracing Assemblies onto each post (component B) and bottom face of a Frame Joist (component E or F). As shown in Fig. 37 & 38.
2. Once the pergola is square, fasten Lateral Bracing Assemblies through pre-drilled holes on Post or Frame Joist using 4 Evolution Self-Drilling Screws (component K) per Lateral Bracing Assembly. As shown in Fig. 39.
3. Fasten Lateral Bracing Brackets through Lateral Bracing Support pre-drilled holes using 2 Evolution Self-Drilling Screws (component K) per Lateral Bracing Bracket. As shown in Fig. 40.

Note:

- Use a level to confirm Posts are square before fastening. Adjust as needed.
- Reference Fig. 41 for mounted Lateral Bracing Assemblies.
- Stickers should be covered by mating components if install correctly.
- If the pergola is out of square, the pre-drilled post holes will need to be re-drilled using a 1/16" [2mm] drill bit.
- **Be sure pre-drilled holes on the Lateral Bracing Assemblies and Posts/Frame Joists are aligned before fastening.**

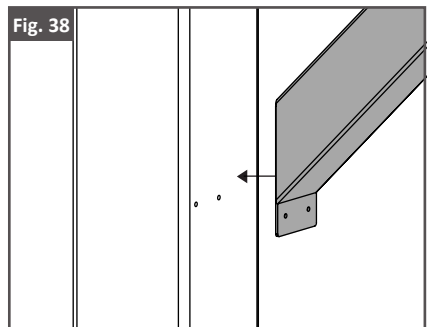
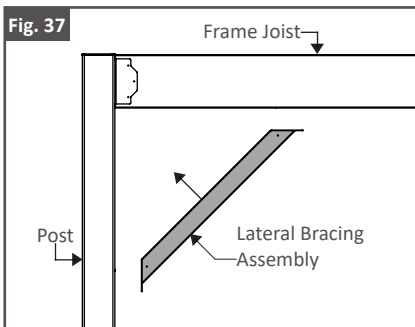

Fig. 39

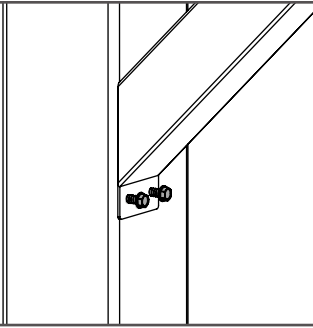

Fig. 40

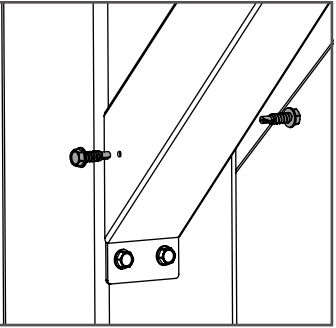
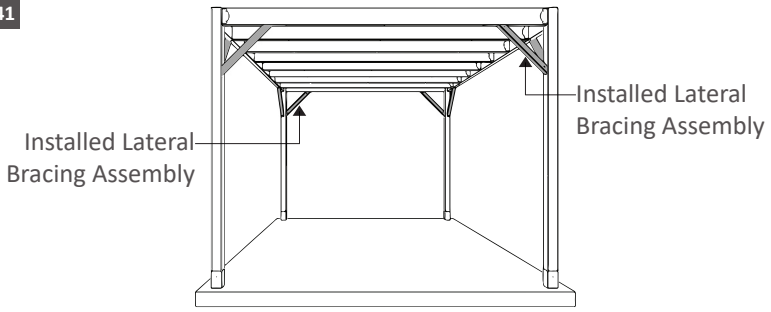

Fig. 41



Step 10: Apply Spray Paint to Scratched Areas

1. Identify the areas of the pergola that have been scratched during installation and apply two coats of Fortress Black Sand Touch Up Paint.

Fig. 42

2X

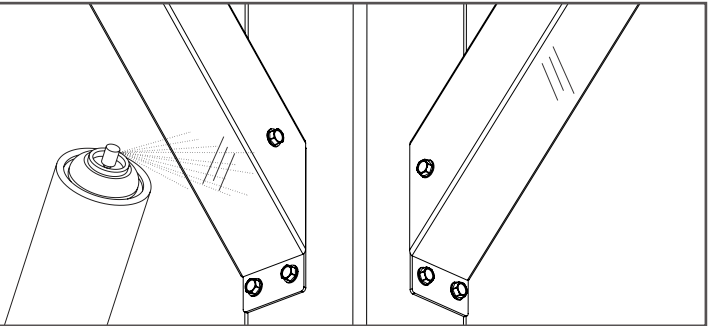

CARE & MAINTENANCE

Care And Maintenance Of Fortress Building Products Powder-Coated Products And Surfaces:

- Immediately after installation of your Fortress Building Products, clean powder-coated products and surfaces with a solution of warm water and non-abrasive, pH neutral detergent solution. Surfaces should be thoroughly rinsed after cleaning to remove all residues. All surfaces should be cleaned using a soft cloth or sponge.
- Ensure construction materials such as concrete, plaster, and paint splashes are removed immediately before they have a chance to dry. Failure to remove these materials may cause damage to the powder-coated surfaces.
- **DO NOT** allow metal shavings and/or chips to get dropped or blown into a pool, hot tub, or any other body of water. Staining could occur if this were to happen.
- The frequency of cleaning depends in part on the standard of appearance and also the requirements to remove deposits that may cause damage to the powder coating after prolonged exposure. Fortress recommends cleaning in three to four monthly intervals.
- **WARNING: Do not use strong solvents such as thinners, or solutions containing chlorinated hydrocarbons, esters, or ketones. Abrasive cleaners or cutting compounds should not be used.**

WARRANTY

To obtain and review a copy of the warranty, please go to: <https://Fortressbp.com/warranties>. You can also contact: (844) 909-1999 or write to: Fortress Building Products Warranty, 1720 N 1st St, Garland, TX 75040 to obtain a copy of the warranty.



JOIN THE REVOLUTION.

FortressBP.com | 866.323.4766